

Visual Merchandising (Creo™)

Applicable Products:

CR Double Pole - 84" Height
with Plasma

**NOTE: Most upright components must be installed before completing unit assembly.
End user determines component location.**

1. Press bottom crossbar into base upright channels (fig. A).
2. Slide uprights over base uprights and tighten knobs to secure, using cone top as a tightening tool (fig. B).
3. Attach the 12.375", followed by the lower plasma bracket crossbar, by repeating the connections of steps 1 and 2 (fig. C).
4. Attach the 17.625" uprights to the 12.375" uprights and tighten knobs to secure, using cone top as a tightening tool (fig. C).
5. Press top crossbar into upright channels (fig. D).
6. Slide cones over uprights and tighten cones to secure (fig. E).

NOTE: Although model shown below may differ from your model, assembly instructions remain the same.

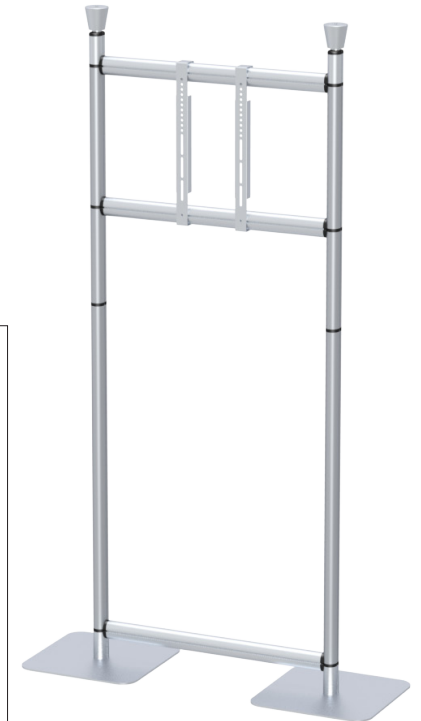
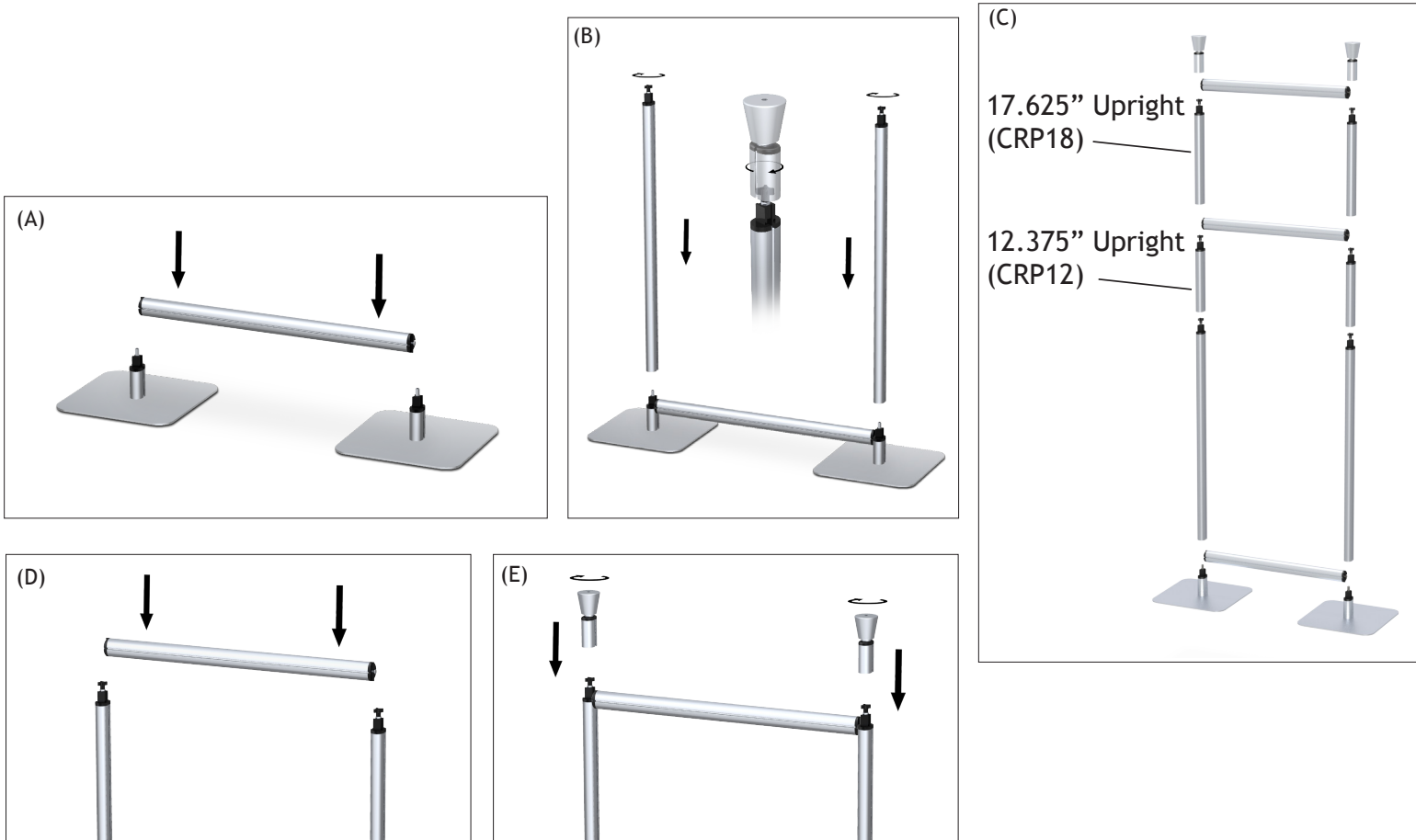

Visual Merchandising (Creo™)

Applicable Products:

Plasma Brackets (CRPB)

**NOTE: Most upright components must be installed before completing unit assembly.
End user determines component location.**

1. Insert puck glides into bottom crossbar channel (fig. A-1). Slide puck glides to desired location (fig. A-2).
2. Hook video bracket over top crossbar (fig. B-1) and align bottom hole with puck glide on bottom crossbar (fig. B-2).
3. Screw puck onto puck glide to secure brackets (fig. C-1 & fig. C-2).
4. Screw TV unit onto brackets (fig. D).

